

## Installation and Operating Instruction for Brake Caliper HI 150 HUK and HI 180 HUK

E 09.734e



Any questions? Please contact us.

<b>RINGSPANN</b>	<b>Installation and Operating Instructions for Brake Caliper HI 150 HUK and HI 180 HUK hydraulically activated without Brake Pad Retraction</b>	<b>E 09.734e</b>			
Date: 14.02.2013	Issue : 3	draw.: Su	checked: Ei	Pages: 16	Page: 2

---

## IMPORTANT

Please read these instructions carefully before installing and operating the product. Your particular attention is drawn to the notes on safety.

These installation and operating instructions are valid on condition that the product meets the selection criteria for its proper use. Selection and design of the product is not the subject of these installation and operating instructions.

Disregarding or misinterpreting these installation and operating instructions invalidates any product liability or warranty by RINGSPANN; the same applies if the product is taken apart or changed.

These installation and operating instructions should be kept in a safe place and should accompany the product if it is passed on to others – either on its own or as part of a machine – to make it accessible to the user.

---

## SAFETY NOTICE

- Installation and operation of this product should only be carried out by skilled personnel.
- Repairs may only be carried out by the manufacturer or accredited RINGSPANN agents.
- If a malfunction is indicated, the product or the machine into which it is installed, should be stopped immediately and either RINGSPANN or an accredited RINGSPANN agent should be informed.
- Switch off the power supply before commencing work on electrical components.
- Rotating machine elements must be protected by the purchaser to prevent accidental contact.
- Supplies abroad are subject to the safety laws prevailing in those countries.

<b>RINGSPANN</b>	<b>Installation and Operating Instructions for Brake Caliper HI 150 HUK and HI 180 HUK hydraulically activated without Brake Pad Retraction</b>			<b>E 09.734e</b>	
	Date: 14.02.2013	Issue : 3	draw.: Su	checked: Ei	Pages: 16    Page: 3

## Contents

### 1. General remarks

- 1.1 General safety instructions
- 1.2 Special safety instructions

### 2. Configuration and function / Parts list

- 2.1 Function
- 2.2 Drawing and Part List

### 3. Condition on delivery

### 4. Installing the RINGSPANN brake caliper

- 4.1 Handling
- 4.2 Cleaning the brake disc
- 4.3 Cleaning the mounting surfaces
- 4.4 Mounting the brake pads
- 4.5 Installing the brake
- 4.6 Control of mounting position
- 4.7 Bleeding the brake
- 4.8 Running-in procedure of the brake pads
- 4.9 Connecting of the wear alarm cable (optional)
- 4.10 Dismantling the brake

### 5. Maintenance

- 5.1 General maintenance
- 5.2 Brake pad wear control

### 6. Replacing consumable parts

- 6.1 Brake pads
- 6.2 Piston gaskets

### 7. Annex

- 7.1 A - Dimensions, oil connections, tightening torques
- 7.2 B - Installation, at interior assembly
- 7.3 C - Installation, at exterior assembly

<b>RINGSPANN</b>	<b>Installation and Operating Instructions for Brake Caliper HI 150 HUK and HI 180 HUK hydraulically activated without Brake Pad Retraction</b>			<b>E 09.734e</b>	
	Date: 14.02.2013	Issue : 3	draw.: Su	checked: Ei	Pages: 16    Page: 4

## 1. General remarks

These operating instructions apply to

- series HI 150 HUK and HI 180 HUK .
- the various brake pad materials as well as brake pads with wear alarm cables.
- Installation on vertical brake discs (on horizontal shafts) and on horizontal brake discs.

Please refer to the drawings in the individual sections.

## 2. Configuration and function / Parts list

### 2.1 Function

The brake caliper is used as a parking (holding) brake and a stopping brake.

The braking force is generated with pressure oil, a brake pad retraction does not take place.

Rotating components (e.g. brake disc) must be secured by the operator to prevent accidental contact.



### **Danger to life and limb !**

**It is essential to secure the entire drive train against inadvertent starts during brake installation and maintenance. Rotating components can cause severe injuries.**

**Therefore, rotating components (e.g. brake disc) must be secured by the operator to prevent accidental contact.**

## 2.2 Drawing and Part List

### Brake caliper HI 150 HUK

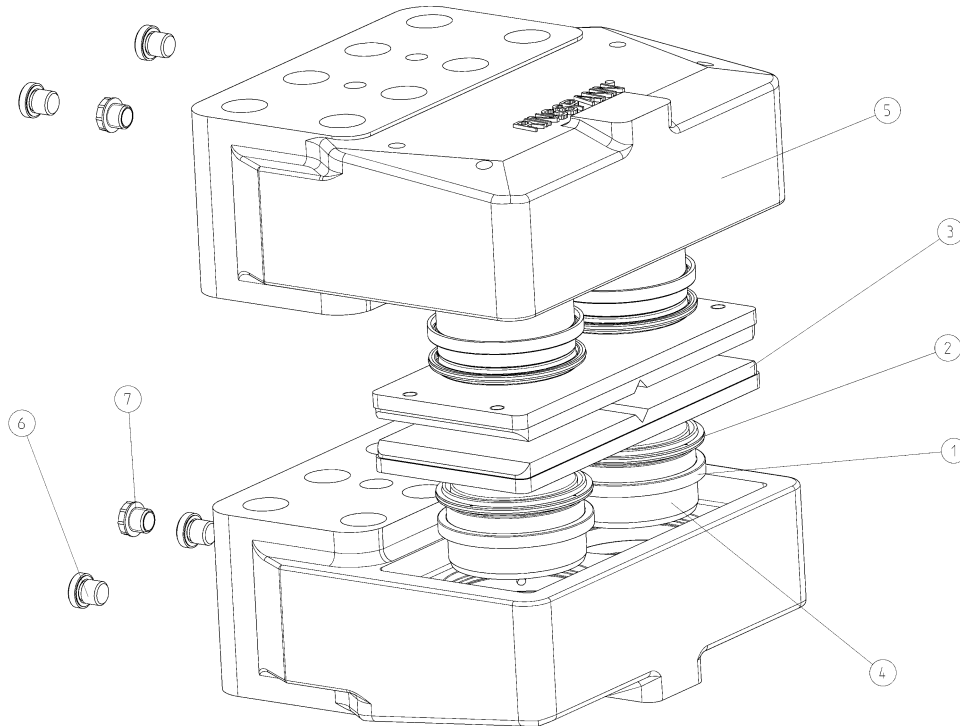

Fig. 2.1

Part	Nomenclature	Quantity	Part number
1	Rod seal	4	5155.075.002.000000
2	Double wiper	4	5139.075.301.000000
3	Standard brake pad for Brake caliper 4458.452.003.000000	1	2472.975.000.A00105*
	Brake pad with wear alarm cable for Brake caliper 4458.452.003.A00109	1	2472.975.000.A00109*
4	Brake piston	4	2478.075.901.000000
5	Brake caliper housing	2	2478.260.003.000000
6	Screw plug G-A 1/4" DIN 908	4	5017.013.303.000000
7	Stopper plug R 1/4"	2	5025.013.205.000000

\*) Part number for 1 set (2 pieces) Brake pads

### Brake caliper HI 180 HUK

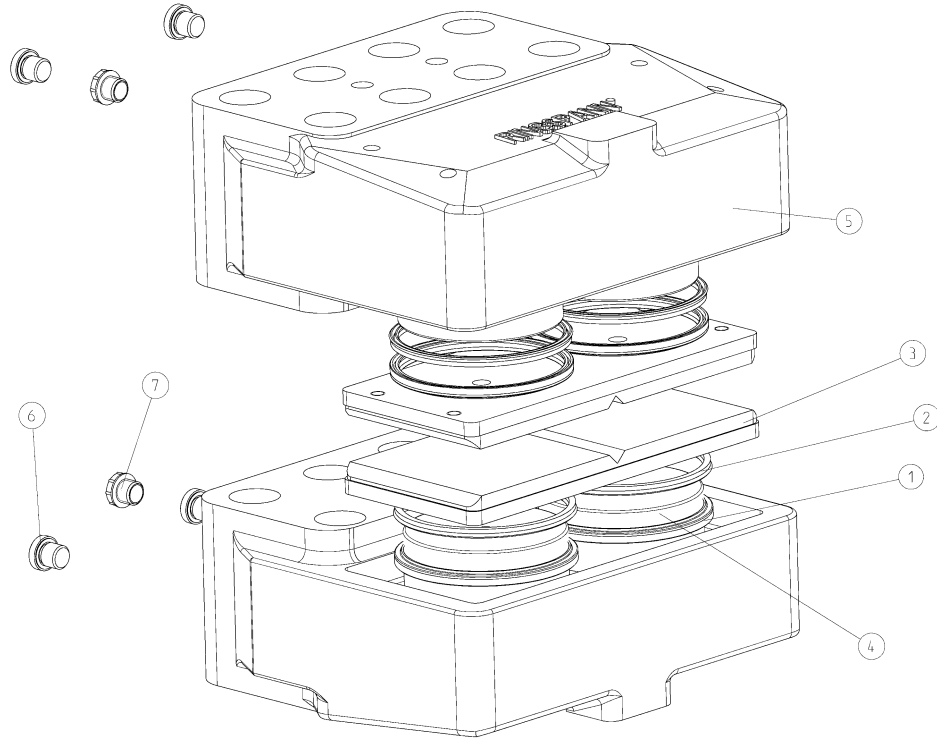

Fig. 2.2

Part	Nomenclature	Quantity	Part number
1	Rod seal	4	5155.090.050.000000
2	Double wiper	4	5139.090.080.000000
3	Standard brake pad for Brake caliper 4458.552.003.000000	1	2472.975.000.A00105*
	Brake pad with wear alarm cable for Brake caliper 4458.552.003.A00109	1	2472.975.000.A00109*
4	Brake piston	4	2478.090.901.000000
5	Brake caliper housing	2	2478.260.002.000000
6	Screw plug G-A ¼" DIN 908	4	5017.013.303.000000
7	Stopper plug R ¼"	2	5025.013.205.000000

\*) Part number for 1 set (2 pieces) Brake pads

<b>RINGSPANN</b>	<b>Installation and Operating Instructions for Brake Caliper HI 150 HUK and HI 180 HUK hydraulically activated without Brake Pad Retraction</b>			<b>E 09.734e</b>	
	Date: 14.02.2013	Issue : 3	draw.: Su	checked: Ei	Pages: 16    Page: 7

### 3. Condition on delivery

The brake caliper is delivered as two brake caliper halves with 1 set of brake pads.

### 4. Installing the RINGSPANN brake caliper

#### 4.1 Handling

Each brake caliper-half weighs approximately 35 kg. A threaded transport bore is provided for lifting ((see Annex A, page 14).

#### 4.2 Cleaning the brake disc

Before installing the brake, the brake disc must be cleaned with alcohol, e.g. ethyl or isopropyl alcohol, or a water-based surfactant solution (soapy water, etc.) and then rubbed dry with a clean cloth.

When cleaning the brake disc with a thinner, acetone or a brake cleaning agent, it is important to ensure that neither these cleaners nor any cleaner residues come in contact with the brake pads. This is especially important in the case of brakes used only as parking brakes, as no dynamic braking operations take place during which thinner residues would be rubbed off the brake disc.



#### **Caution!**

Oil and rust-proofing-agent residues reduced friction coefficient and thus diminish transmissible braking torque substantially!

#### 4.3 Cleaning the mounting surfaces

The mounting surfaces on the brake caliper halves and the mounting flange (supplied by the customer) are to be cleaned in the same manner as the brake disc.

#### 4.4 Mounting the brake pads

The brake pads (3) are delivered in separate packaging. In order to prevent brake pads soiling, the brake pads should not be removed from the packaging until immediately before they are to be mounted. Brake pads that come in contact with grease or oil are no longer suitable for use and must be replaced immediately. Brake pads made of sintered metal are less sensitive and can be reused after cleaning with a solvent.

The brake caliper half must be installed together with the brake pad.



#### **Caution!**

The two halves of the brake caliper must not be exposed to hydraulic pressure during assembly/installation.

#### 4.5 Mounting the brake

To ensure screech- and noise-free braking, the brake caliper should be mounted on stable, low-vibration machine components.

<b>RINGSPANN</b>	<b>Installation and Operating Instructions for Brake Caliper HI 150 HUK and HI 180 HUK hydraulically activated without Brake Pad Retraction</b>			<b>E 09.734e</b>	
	Date: 14.02.2013	Issue : 3	draw.: Su	checked: Ei	Pages: 16    Page: 8

The brake caliper is provided for a thickness of 30 mm of brake disc. Thereby, the distance between the brake disc and brake pads is each 1.5 mm. When using a thicker brake disc must a corresponding spacer between the two brake caliper halves be installed.

- Before installing the brake caliper, check to ensure that the mounting surface is even and concentric run between the brake disc and the mounting surface is within the prescribed tolerance range (see Annex B, "Installation, at interior assembly", page 15 or Annex C "Installation, at exterior assembly", page 16).
- Position the brake caliper-half with the inserted brake pads and tighten the mounting bolts/screws with little pretension.
- Check to ensure that the brake disc can be turned without resistance. The distance between the brake disc and the brake caliper should be approx.  $0.001 \times d$  ( $d$  = brake disc diameter), so that the brake disc can rotate freely even at increased temperatures.
- Tighten the mounting bolts/screws with the specified tightening torque (see Annex A, page 14).
- Mount the oil pressure- and oil leak connections (see Annex A, page 14).



**Caution!**

Check to ensure that the brake disc rotates freely.



**Information!**

For easier installation, you can fix the position of the brake at first with only one screw before you swing the brake to the point where the rest of the screws can be mounted.

Maximum operating pressure is 160 bar. The two piston bores are connected in the pressure area. There are always two oil pressure ports located on each caliper half. Alloyed mineral oil, Group HLP as defined in DIN 51525 or API to classification SC, SD or SE, can be used as pressure fluid.

HW 150 HFA : Oil volume per 1 mm of piston stroke =  $17 \text{ cm}^3$  per brake caliper  
(1 caliper = 2 halves)  
max. oil volume (at max. brake pad wear) =  $128 \text{ cm}^3$  per brake caliper

HW 180 HFA : Oil volume per 1 mm of piston stroke =  $26 \text{ cm}^3$  per brake caliper  
(1 caliper = 2 halves)  
max. oil volume (at max. brake pad wear) =  $195 \text{ cm}^3$  per brake caliper



<b>RINGSPANN</b>	<b>Installation and Operating Instructions for Brake Caliper HI 150 HUK and HI 180 HUK hydraulically activated without Brake Pad Retraction</b>			<b>E 09.734e</b>	
	Date: 14.02.2013	Issue : 3	draw.: Su	checked: Ei	Pages: 16   Page: 9



**Caution!**

For the connection of the pressure and drain connections should be flexible hydraulic hoses are used to restrict the movement of the brake not.



**Caution!**

Oil expelled from the system must be removed completely. Leaks must be repaired immediately.



**Information!**

The purer the hydraulic fluid, the longer service life of the brake system.

4.6 Control of mounting position

- Check to ensure that the permissible angular offset between the brake disc and the mounting surface is not exceeded (see Annex B, "Installation, at interior assembly", page 15 or Annex C, "Installation, at exterior assembly", page 16).
- Check the axial movement of the brake disc. Axial movement must not exceed  $\pm 0.3$  mm.



**Caution!**

During installation, ensure that the brake pads are centred and in full contact with the surface of the brake disc.  
Please observe maximum the wear limit.

4.7 Bleeding the brake

For initial installation, gasket replacement or other work performed on the hydraulic system the hydraulic system must be bled.

If the system is designed for circulation from hydraulic oil, the hydraulic system can be bled by circulating the hydraulic oil.

4.8 Running-in procedure of the brake pads

Full-surface contact between the two brake pads (3) and the brake disc as well as brief heating of the brake pads to approx. 200°C are required to ensure optimum braking. Therefore, multiple brief braking operations (running in) must performed while the brake disc is rotating.

This is not necessary if the brake is used in an azimuth brake system in a wind turbine.



**Caution!**

If the brake pads cannot be run in, the torques listed in our Publication 46 cannot be achieved. Reductions of up to 50% are possible.



**Caution!**

If the brake are used as parking (holding) brake, the specified torques cannot be achieved. Reductions of up to 50% are possible.

4.9 Connecting of the wear alarm cable (optional)

Connect the wear alarm cable to a 24V control voltage source, e.g. via a signal light. When the maximum permissible brake pad wear thickness is reached, a contact comes established with the neutral conductor and the signal lamp lights up.

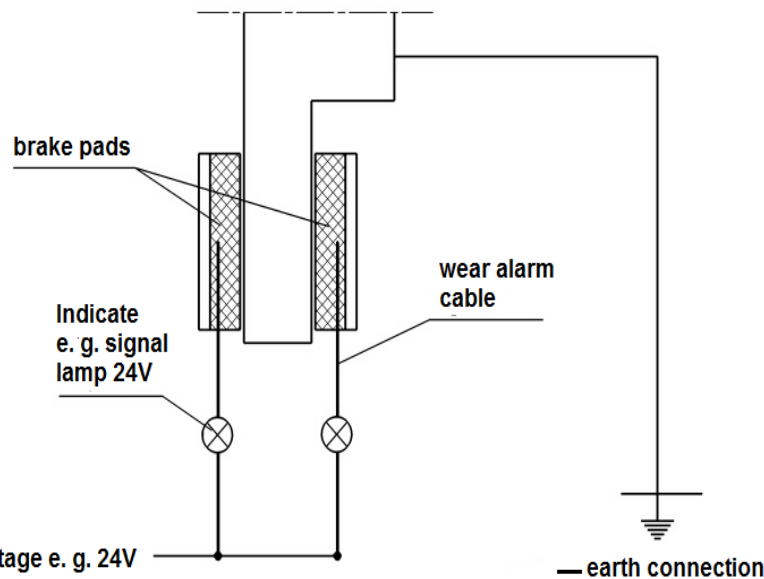

Fig. 4.1 + Controll voltage e. g. 24V

4.10 Dismantling the brake

Make sure that no pressure is exerted on the brake caliper and disconnect the hydraulic lines from the brake caliper halves.

Remove the mounting bolts/screws. The brake caliper can then be removed from the mounting surfaces.

<b>RINGSPANN</b>	<b>Installation and Operating Instructions for Brake Caliper HI 150 HUK and HI 180 HUK hydraulically activated without Brake Pad Retraction</b>			<b>E 09.734e</b>	
	Date: 14.02.2013	Issue : 3	draw.: Su	checked: Ei	Pages: 16 Page: 11



**Danger to life and limb!**

When disassembling the brake it is essential to ensure that the entire drive train is secured against inadvertent activation. Rotating components can cause severe injuries. Therefore, rotating components (e.g. brake discs) must be secured against accidental contact. To prevent injuries to personnel, secure the brake with the aid of an assembly locking device.



**Caution!**

Ensure that no hydraulic pressure is applied to the brake caliper.



**Caution!**

Secure the brake for disassembly.



**Caution!**

Brake pads must not come in contact with lubricants.

## 5. Maintenance

Maintenance must be performed on the brake caliper at intervals of between 4 and 12 weeks, depending upon the frequency and duration of operation.

### 5.1 General maintenance

- Check the bolt connection between the brake caliper and the machine component for solid compound.
- Check the hydraulic lines and -connections for leaks.
- Check the brake piston gasket system for proper seal by inspecting the oil leak lines. If there is oil in the oil leak lines, the gasket must be replaced (see Section 6.2).



**Caution!**

Brake pads must not come in contact with hydraulic oil.

### 5.2 Brake pad wear control

Brake pad material must not be worn to less than 2 mm from the steel base plate. The brake pads (3) must always be replaced in pairs.

<b>RINGSPANN</b>	<b>Installation and Operating Instructions for Brake Caliper HI 150 HUK and HI 180 HUK hydraulically activated without Brake Pad Retraction</b>			<b>E 09.734e</b>	
	Date: 14.02.2013	Issue : 3	draw.: Su	checked: Ei	Pages: 16   Page: 12

## 6. Replacing consumable parts

### 6.1 Brake pads

Before replacing the brake pads (3), make sure that the mass held by the brake is secured in a fixed position, since the brake will be released in order to replace the brake pads.

- Make sure that no oil pressure is applied to the brake caliper and solve the hydraulic fittings at the caliper halves.
- Remove 7 of the 8 mounting bolts/screws. Use the remaining 8<sup>th</sup> screw as a pivot and swing the brake caliper away from the disc.
- Press the old brake pads about the 4 holes out of the brake caliper housing and replace them with new pads.
- Swing the brake caliper back into position, replace the previously removed seven mounting bolts/screws back and screw this with the specified tightening torque (see Annex A, page 14).
- Reconnect the hydraulic lines to the brake caliper halves and switch on the hydraulic pressure system. Check the hydraulic lines for leaks.
- The brake caliper is now ready for the running-in operation (see Section 4.8).



#### Caution!

The brake pad spacing adjustment must be repeated after initial installation or after replacement of brake pads.



#### Danger to life and limb!

Brake pads may be replaced only when the equipment system and/or the working machine is at a complete standstill!



#### Caution!

Ensure before replacement the brake pads that no hydraulic pressure is applied to the brake caliper.

### 6.2 Piston gaskets

Before replacing the piston gaskets, make sure that the mass held by the brake is secured in a fixed position, since the brake will be released in order to replace the piston gaskets.

Maximum possible cleanliness is essential when working on the hydraulic system. Each part must be cleaned in solvent, dried and stored protected in a dust-free place. Dirt reduces the service life of the gaskets substantially. Check the surfaces of the brake pistons for damage. Surface damage can destroy a gasket immediately.

<b>RINGSPANN</b>	<b>Installation and Operating Instructions for Brake Caliper HI 150 HUK and HI 180 HUK hydraulically activated without Brake Pad Retraction</b>			<b>E 09.734e</b>	
	Date: 14.02.2013	Issue : 3	draw.: Su	checked: Ei	Pages: 16   Page: 13

- Make sure that no oil pressure is applied to the brake caliper and solve the hydraulic fittings at the caliper halves.
- Remove the brake caliper halves from the mounting flange. Press the brake pistons (4) with compressed air, connected with the oil pressure-port, carefully out of the brake caliper housing (5).
- Remove the old gasket (1) and the old double wiper (2) and inserting the new gasket and the new double wiper in the brake caliper housing (5). Ensure the correct position of the gasket (see Fig. 2). The gasket should be installed by hand only, in order to ensure that the sealing edge is not damaged. To facilitate replacement, the gasket and the double wiper can be bent in kidney shaped and are fitted into the groove. Apply a light coat of oil to the gasket and press the cleaned brake pistons (4) carefully into the brake caliper housing (5).

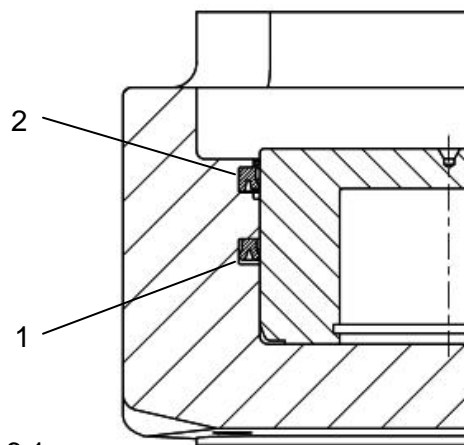

Fig. 6.1



**Danger to life and limb!**

Seals/gaskets may be replaced only with the equipment system and/or working machine is at a complete standstill!



**Caution!**

Ensure that no hydraulic pressure is applied to the brake caliper. Observe the manufacturer's instructions when handling solvents.



**Caution!**

Document the configuration and number of disc springs and support disc for easy installation.

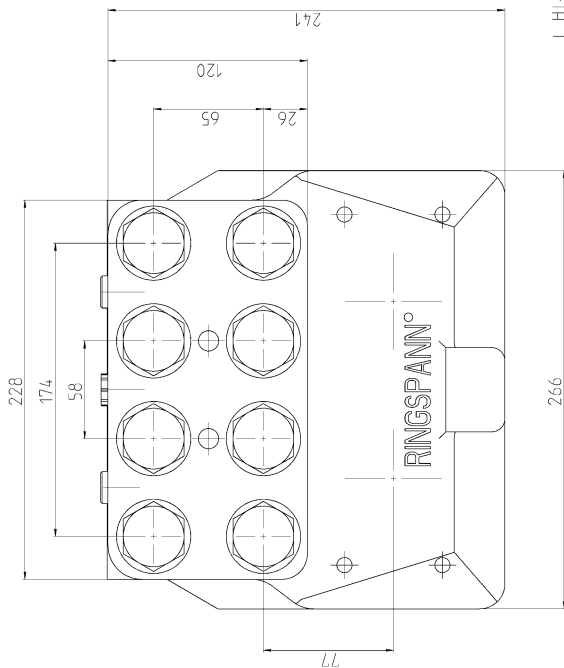
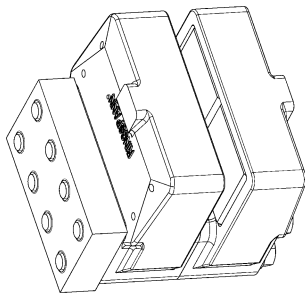
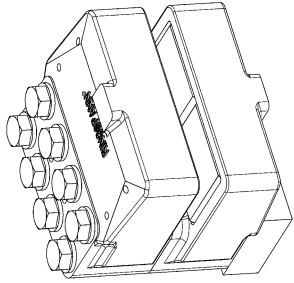

HI-150-HUK: screws M24 - 12.9 (are not included in delivery)  
tightening torque 880 Nm; lubricated with MoS2  
HI-180-HUK: screws M27 - 12.9 (are not included in delivery)  
tightening torque 1290 Nm; lubricated with MoS2

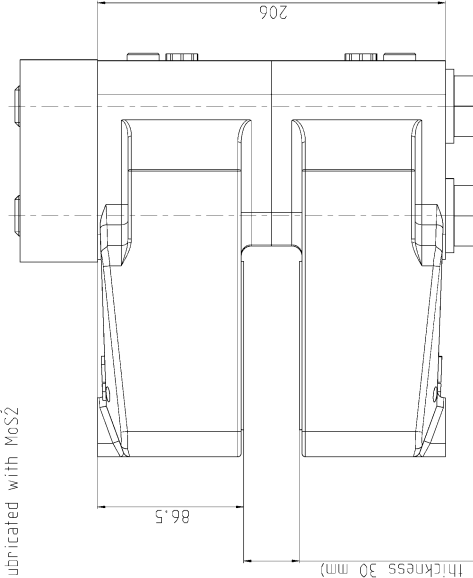
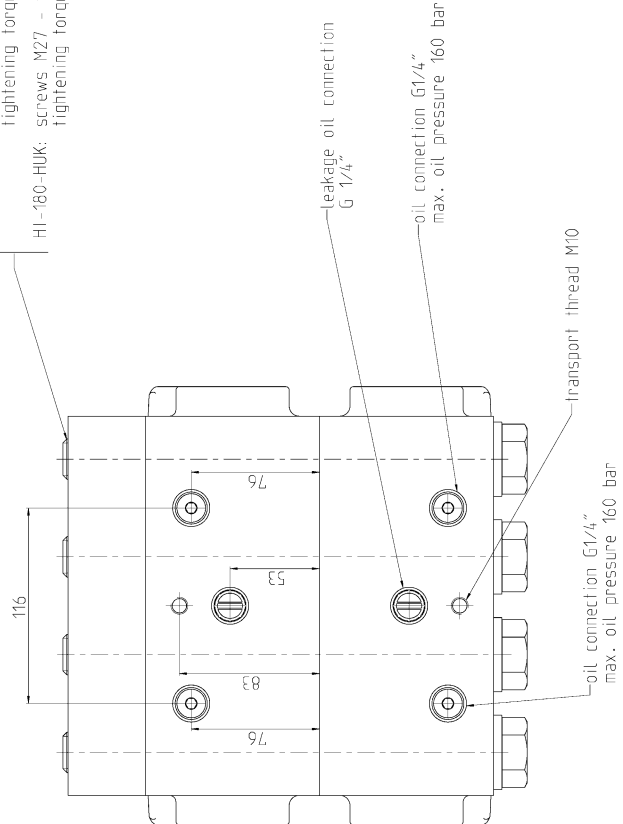

Annex A  
Dimensions, oil connections, tightening torques

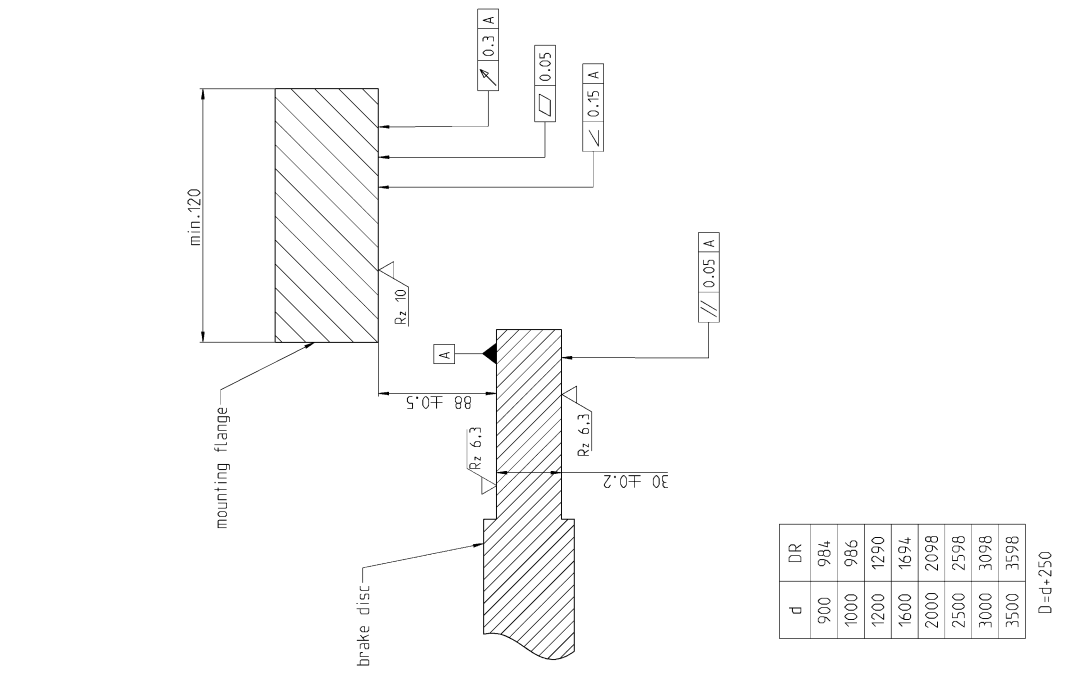

Annex B  
installation, at interior assembly

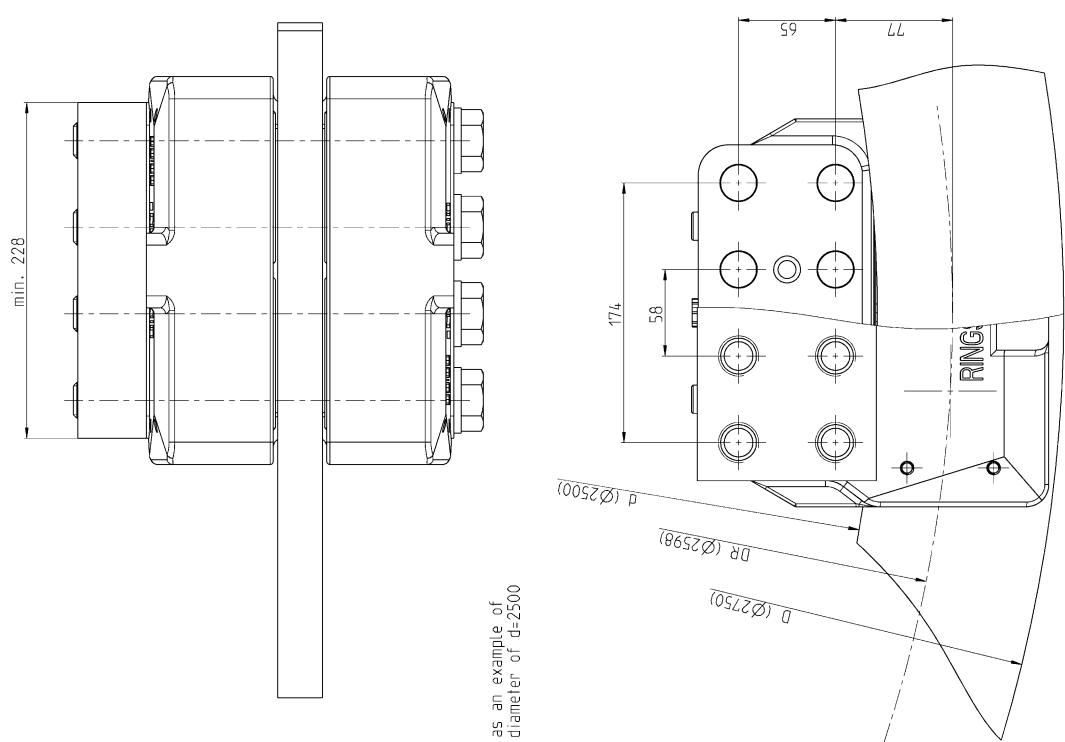

Figures in () as an example of a brake disc diameter of d=2500

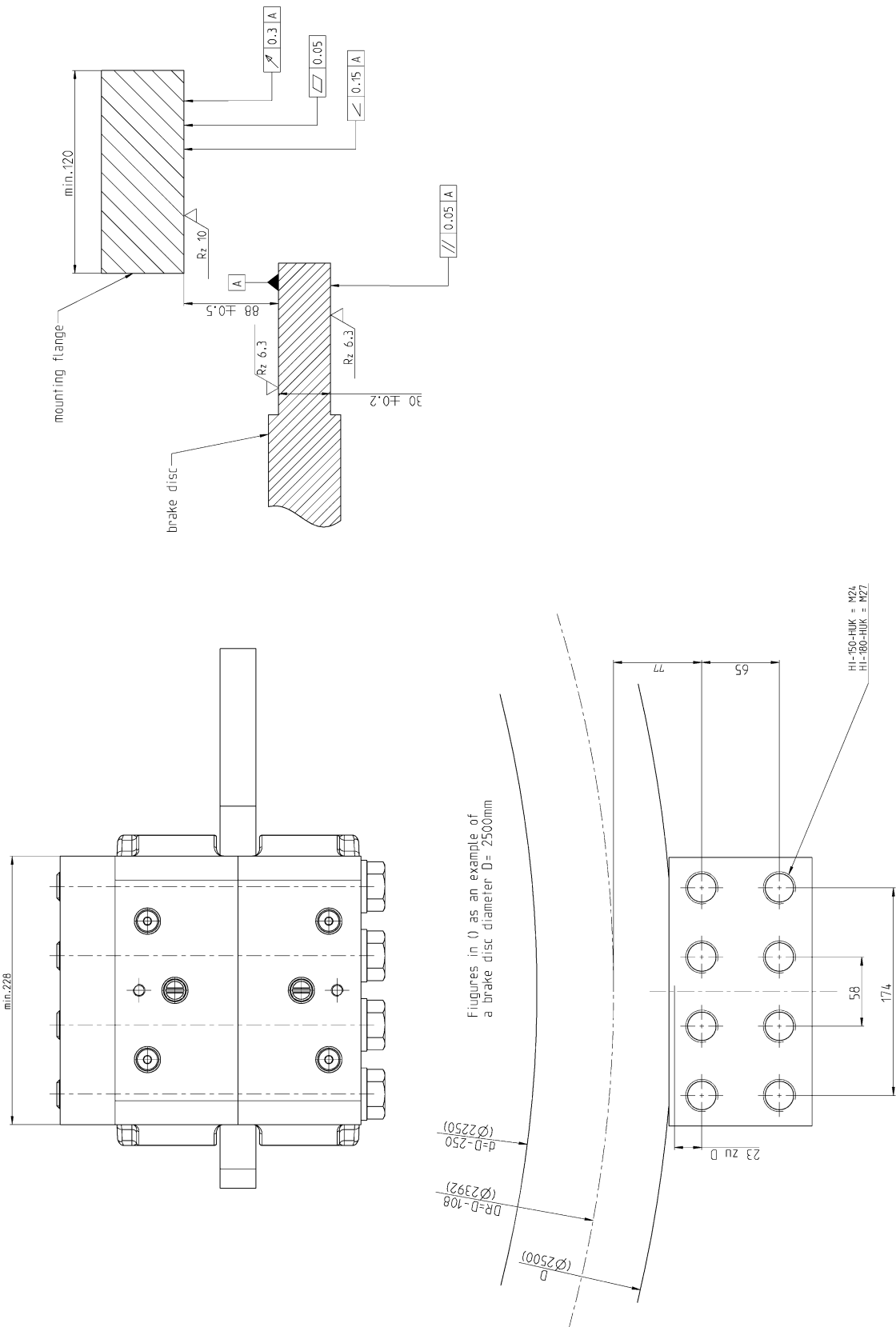

Annex C  
installation, at exterior assembly